

Resolution No. 2014 - 8
RESOLUTION TO ORDER THE IMPROVEMENT OF LARKSPUR LANE (TR 154)
Russell Township, Geauga County

WHEREAS, the Russell Township Board of Trustees, Geauga County, has determined by unanimous vote in Resolution No. 2014-5 that the public convenience and welfare require the improvement of the entire length of Larkspur Lane (TR 154) in Russell Township, and authorized the Geauga County Engineer to prepare engineering plans in accordance with Section 5573.01 of the Ohio Revised Code; and

WHEREAS, the Geauga County Engineer has completed the plans, profiles, cross sections, estimates, and specifications for the improvement of the entire length of Larkspur Lane (TR 154) in Russell Township, and has filed the specifications with the Board; and

WHEREAS, the Russell Township Board of Trustees has reviewed the plans, profiles, cross sections, estimates, and specifications and finds them acceptable; and

WHEREAS, the cost of such improvement will not be excessive in view of the public utility thereof; and

WHEREAS, the Russell Township Board of Trustees is satisfied that the public convenience and welfare require the proposed improvement of the entire length of Larkspur Lane (TR 154) in Russell Township.

NOW THEREFORE, BE IT RESOLVED that the Russell Township Board of Trustees in accordance with Section 5573.06 of the Ohio Revised Code hereby orders that such improvement proceed.

BE IT FURTHER RESOLVED that the Russell Township Board of Trustees hereby adopts the surveys, plans, profiles, cross sections, estimates, and specifications for such improvement, the costs of which shall be paid from local funding sources in accordance with Section 5573.07 of the Ohio Revised Code.

BE IT FURTHER RESOLVED that the Fiscal Officer of the Russell Township Board of Trustees is hereby ordered to let this project for bids in accordance with Section 5575.02 of the Revised Code. The bids shall be let upon a unit price basis. Bids shall be received by Charles Walder, Fiscal Officer, until 1:00 P.M. official local time on May 7, 2014. Bids received will be publicly opened and read aloud at 1:15 P.M. the same day at the Russell Fire-Rescue Department.

BE IT FURTHER RESOLVED that the Fiscal Officer of the Russell Township Board of Trustees is hereby instructed to transmit a certified copy of this resolution to the Geauga County Engineer.

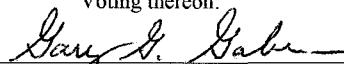
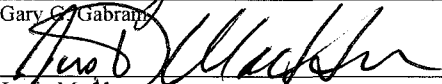
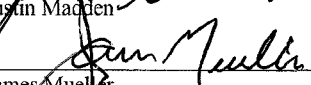
Voting thereon:	Vote
 _____ Gary G. Gabran	<u>aye</u>
 _____ Justin Madden	<u>aye</u>
 _____ James Mueller	<u>aye</u>

I, Charles Walder, the Fiscal Officer of the Russell Township Board of Trustees, Geauga County, Ohio certify that the foregoing is a true and correct copy of a resolution adopted at a legally convened Board meeting held on 4/16, 2014.



Charles Walder, Fiscal Officer

**RUSSELL TOWNSHIP
GEAUGA COUNTY, OHIO**

Bid Specifications

**The Asphalt Resurfacing of Larkspur Lane, TR 154
Russell Township**

Contract RUS-154-14

Bids Received By: May 7, 2014
1:00 P.M.
Administration Building
c/o Charles Walder
8501 Kinsman Road
Novelty, OH 44072

Bids Opened: May 7, 2014
1:15 P.M.
Fire-Rescue Dept.
14810 Chillicothe Road
Novelty, OH 44072

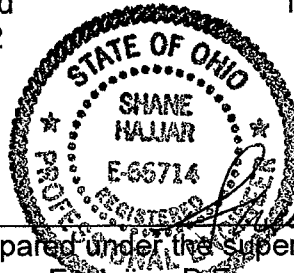

Prepared under the supervision of
Shane E. Hajar, P.E. P.E. 66714
Date 4/11/14 Geauga County Deputy Engineer

**Plans/Specifications Approved by
Russell Township Board of Trustees**

Gary G. Gabram
Gary G. Gabram

Date 4/16/14

Justin Madden
Justin Madden

Date 4/16/14

James Mueller
James Mueller

Date 4/16/14

LEGAL NOTICE

Russell Township

Notice is hereby given that sealed bids will be received by the Russell Township Board of Trustees, c/o Charles Walder, Fiscal Officer, P.O. Box 522, 8501 Kinsman Road, Novelty, Ohio 44072 until 1:00 P.M. official local time on May 7, 2014. Bids received will be publicly opened and read aloud at 1:15 P.M. the same day at the Fire-Rescue Department located at 14810 Chillicothe Road, Novelty, OH 44072 for **The Asphalt Resurfacing of Larkspur Lane, TR 154** in Russell Township. The Engineer's estimate for this project is \$55,000.00.

Copies of the plans and/or specifications may be obtained digitally online at <http://www.co.geauga.oh.us/Departments/Engineer/OnlinePlans.aspx> or a hardcopy is available at the Geauga County Engineer's Office, 470 Center Street, Building 5, Chardon, OH 44024.

A bid guaranty in the amount of one hundred percent (100%) of the bid amount or a certified check, cashier's check or letter of credit pursuant to Chapter 1305 of the Ohio Revised Code in the amount of ten percent (10%) of the total bid amount shall accompany each bid. The bid shall be let upon a unit price basis.

Bids may be held by the Russell Township Board of Trustees for a period not to exceed sixty (60) days from the date of opening, for the purpose of reviewing the bids and investigating the qualifications of bidders, prior to awarding the contract.

The Russell Township Board of Trustees reserves the right to reject any and all bids, to waive any informalities or irregularities in the bids received, and to accept any bid or bids which are deemed most favorable to the Board at the time and under conditions stipulated, all in accord with the applicable provisions of laws of the State of Ohio governing the conduct of the Russell Township Board of Trustees.

BY THE ORDER OF THE RUSSELL TOWNSHIP BOARD OF TRUSTEES

Charles Walder, Fiscal Officer

Publish: April 22, 2014

**LOCATION MAP
LARKSPUR LANE, TR 154
RUS-154-14
RUSSELL TOWNSHIP
GEAUGA COUNTY**

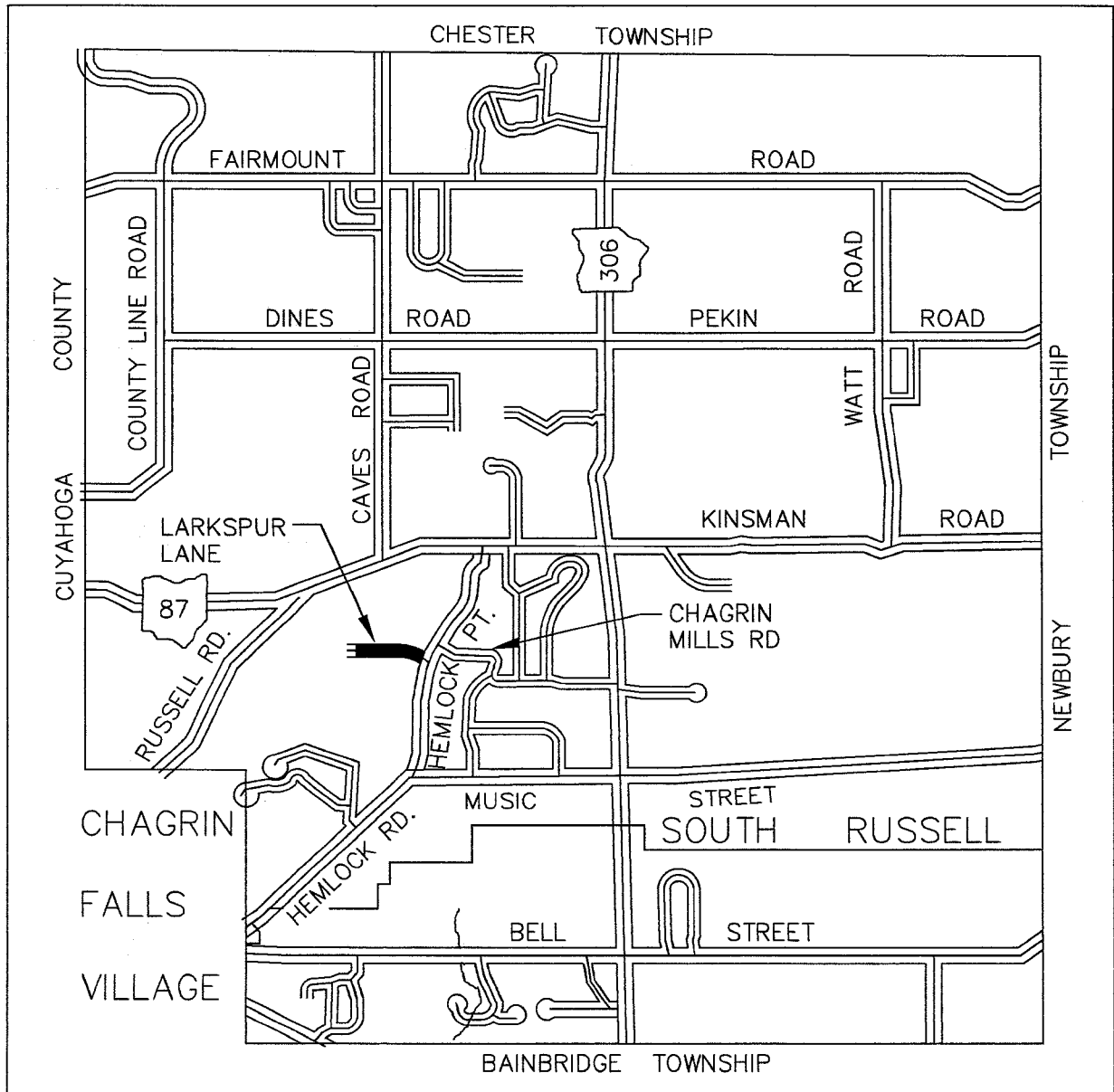

TYPICAL SECTION

The Asphalt Resurfacing of Larkspur Lane, TR 154

Russell Township, Geauga County

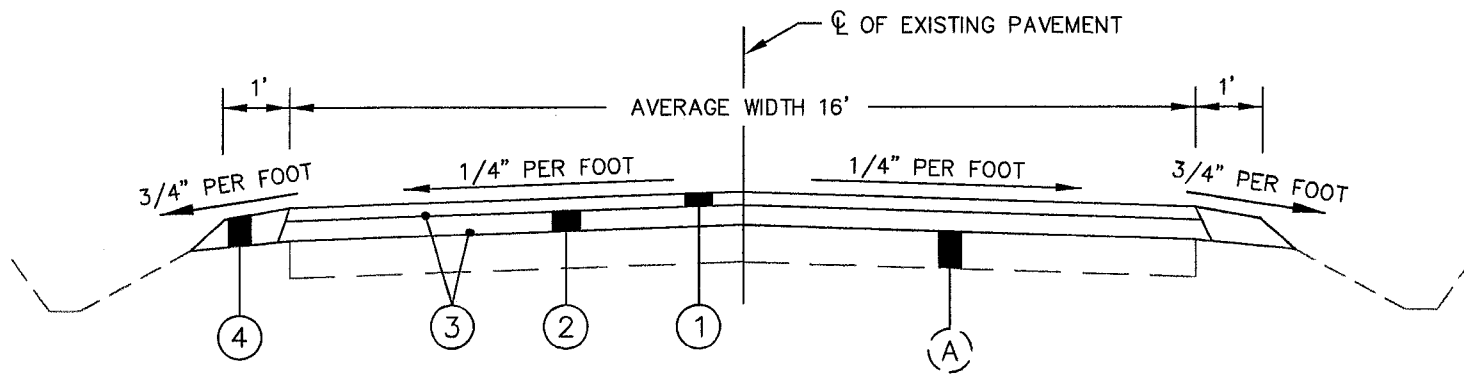

NORMAL SECTION

LEGEND

- ① ITEM 448 - 1.25" ASPHALT CONCRETE, SURFACE COURSE, TYPE 1, PG64-22, AS PER PLAN
- ② ITEM 448 - 2.5" ASPHALT CONCRETE, INTERMEDIATE COURSE, TYPE 2, PG64-22, AS PER PLAN
- ③ ITEM 407 - TACK COAT, AS PER PLAN
- ④ ITEM 617 - 3.75" COMPACTED AGGREGATE (RACP), AS PER PLAN
- (A) EXISTING ASPHALT PAVEMENT

DESCRIPTION OF WORK

The Asphalt Resurfacing of Larkspur Lane, TR 154 Russell Township, Geauga County

Section 1 General

The Construction and Material Specifications dated 2013 published by the Ohio Department of Transportation (ODOT) and the Modifications to the Ohio Department of Transportation's 2013 Construction and Material Specifications and Supplemental Specifications for Geauga County dated 2014 shall govern this project except where otherwise noted in this Specification Booklet. The Standard Contract Provisions for Contracts Prepared by the Geauga County Engineer's Office dated 2014 shall govern the contractual agreement for this project.

These Documents are available on the Geauga County Engineer's Web Site. Go to <http://www.co.geauga.oh.us/Departments/Engineer/OnlinePlans.aspx> for viewing or they may be picked up at the Engineer's office. The requirements of Section 4115 of the Ohio Revised Code with regards to prevailing wages shall be followed for this project.

The project shall include the asphalt resurfacing of the entire length of Larkspur Lane (TR154). The project limits are generally shown on the location map and will be clearly marked by the Engineer. The work shall include the improvement of approximately 0.26 miles of roadway. Station 0+00 is located at the center of the intersection with Hemlock Point Road.

Section 2 Inspection and Notification

A pre-construction conference will be scheduled by the Engineer with the Contractor prior to the start of construction. The Contractor shall submit a detailed Schedule of Operations for approval prior to the pre-construction meeting. The Contractor shall notify the Engineer at least seven (7) days in advance of the beginning of construction, so the Engineer may schedule the inspection.

The Contractor shall notify the local fire department, police and other appropriate agencies that may require the use of the road during emergency situations of the anticipated road work. If any area becomes inaccessible at any time, the Contractor shall immediately notify the agencies of these locations. The Contractor shall schedule his work and coordinate with the local schools as listed below to accommodate the pick-up and delivery of school students if applicable.

PHONE NUMBERS FOR LOCAL OFFICIALS:

Geauga County Sheriff	(440) 279-2050
State Highway Patrol	(440) 564-5477
Novelty Post Office	(440) 338-3746
West Geauga School Dist.	(440) 729-5900
Metzenbaum Center	(440) 729-9406
Russell Township Road Department	(440) 338-5309

Russell Fire Department (440) 338-6161
Russell Police Department (440) 338-6212

The Contractor shall notify all utility companies with facilities within the project area at least two days prior to commencing construction at each location. The utilities listed below may have facilities within the project areas.

UTILITY OWNERS AND CONTACT PERSONNEL

Dominion East Ohio Gas	relocation@dom.com	(330) 664-2409
The Illuminating Co.	Mark Robinson	(440) 717-6845
Time Warner Cable	Larry Bock	(216) 575-8016
Bakerwell, Inc.	Rex Baker	(330) 276-2161

Section 3 Maintaining Traffic

ODOT Item 614 – Maintaining Traffic

Traffic shall be maintained for the duration of the project. The Contractor shall furnish at least two (2) employees to serve as traffic control flaggers and the work zone shall follow the specifications set forth in ODOT SCD MT-97.11. The Contractor may need to use three (3) flaggers when working at the intersection with Hemlock Point Road in order to properly maintain traffic.

All traffic control devices shall be placed at the direction of the Engineer. Additional signs may be required and installed as directed by the Engineer. The Contractor shall furnish and maintain "BUMP" signs (four) at all butt joints for each direction of travel until the asphalt surface course is placed. All work and traffic control devices shall be in accordance with ODOT Item 614 and other applicable portions of the specifications, as well as the Ohio Manual of Uniform Traffic Control Devices. Payment for all labor, equipment and materials shall be included in the Lump Sum contract price for ODOT Item 614, Maintaining Traffic, unless separately itemized in the plan.

Section 4 Construction

ODOT Item 202 – Wearing Course Removed [165.0 S.Y.]

Butt joints, per ODOT SCD BP-3.1, shall be required at the following locations, as marked by the Engineer:

- Larkspur Lane at the intersection with Hemlock Point Road (50 S.Y.)
- End of the Project (at a length of 65') (115 S.Y.)

ODOT Item 407 – Tack Coat, As Per Plan [350 Gallons]

Tack coat shall be applied to the existing chip seal surface prior to the placement of the intermediate course. The Engineer may adjust the application rate of 0.09 gallons per square yard. An additional quantity of tack coat to be placed on the intermediate course of asphalt prior to the placement of the surface course is included in the total quantity for this item. This quantity has been calculated at the application rate of 0.04 gallons per square yard and shall only be used at direction of the Engineer.

ODOT Item 448 – Asphalt Concrete, Intermediate Course, Type 2, PG64-22, As Per Plan [185.0 C.Y.]

The intermediate course shall be placed in one pass at the full width of sixteen feet (16') at an average compacted depth of two and one-half inches (2½"). Mailbox approaches will be paved with this course at the direction of the Engineer. Two (2) rollers shall be used when compacting this course in order to get proper compaction and finish. A vibratory roller, shall serve as the breakdown roller and compact the course with vibration used in only one direction of travel. A pneumatic roller shall be the second roller. The vibratory roller shall also be used as the finish roller.

ODOT Item 448 – Asphalt Concrete, Surface Course, Type 1, PG64-22 (Driveways) [25.0 C.Y.]

The Contractor shall place up to a ten feet (10') long apron at all drives as directed by the Engineer. The paving of these driveways shall be a separate operation from the mainline paving. The lengths of aprons are subject to change at the direction of the Engineer. Driveway aprons shall be placed after the placement of the intermediate course and before the placement of the surface course.

ODOT Item 448 – Asphalt Concrete, Surface Course, Type 1, PG64-22, As Per Plan [100.0 C.Y.]

The surface course shall be placed in one pass at the full width of sixteen feet (16') at an average compacted depth of one and one-quarter inches (1¼"). Mailbox approaches will be paved with this course at the direction of the Engineer. The Contractor shall use two (2) rollers to compact the surface course including one vibratory roller and one tandem roller. The vibratory roller shall be used to breakdown and compact the course with vibration used in only one direction of travel. The tandem roller shall be used as the finish roller. The surface course shall not be placed the same day as the intermediate course.

ODOT Item 617 – Compacted Aggregate (RACP), As Per Plan [35.0 C.Y.]

Upon the completion of the paving, the Contractor shall place the shoulder material. The shoulder material shall not be placed on the same day as the placement of the surface course. The stabilized shoulder shall have a width of one foot (1') and an average depth of three and three-quarter inches (3¾") along the roadway.

The Contractor shall place shoulder back up material along the edges of new aprons back to the ditch-line, as directed by the Engineer. The shoulder material shall wrap all the way around the drive apron on gravel driveways. The shoulder material shall be comprised of recycled asphalt concrete pavement approved by the Engineer. The Contractor shall use a compaction method approved by the Engineer.

Section 5 Quantity Breakdown

Larkspur Lane, TR 154

Length----- 0.26 Miles
Pavement Width----- 16 Feet (Avg.) Shoulder Width ----- 1 Foot
No. of Drives----- 12 Each

ITEM 103	Contract Performance Bond and Premium	1 Lump
ITEM 202	Wearing Course Removed	165.0 Square Yards
ITEM 407	Tack Coat, As Per Plan	350 Gallons
ITEM 448	Asphalt Concrete, Intermediate Course, Type 2, PG64-22, As Per Plan	185.0 Cubic Yards
ITEM 448	Asphalt Concrete, Surface Course, Type 1, PG64-22, As Per Plan	100.0 Cubic Yards
ITEM 448	Asphalt Concrete, Surface Course, Type 1, PG64-22 (Driveways)	25.0 Cubic Yards
ITEM 614	Maintaining Traffic	1 Lump
ITEM 617	Compacted Aggregate (RACP), As Per Plan	35.0 Cubic Yards
ITEM 624	Mobilization	1 Lump

Office of the Geauga County Engineer
ESTIMATE OF COST
The Asphalt Resurfacing of Larkspur Lane, TR 154

Description of Work:

BV 4/11/2014

- Place 2.5" of 448 Intermediate Course, Type 2
- Place 1.25" of 448 Surface Course, Type 1
- Place 1' RACP shoulder material

length - 0.26 Miles
width - 16 Feet (avg.) shoulder width - 1 Foot
of drives - 12 Each

<i>Item</i>	<i>Description</i>	<i>Quantity</i>	<i>Unit Price</i>	<i>Total Price</i>
103	Contract Performance Bond And Premium	1 Lump	\$ 1,000.00	\$ 1,000.00
202	Wearing Course Removed	165 S.Y.	\$ 10.00	\$ 1,650.00
407	Tack Coat, As Per Plan	350 Gal.	\$ 2.50	\$ 875.00
448	Asphalt Concrete, Intermediate Course, Type 2, PG 64-22, As Per Plan	185.0 C.Y.	\$ 140.00	\$ 25,900.00
448	Asphalt Concrete, Surface Course, Type 1, PG 64-22, As Per Plan	100.0 C.Y.	\$ 150.00	\$ 15,000.00
448	Asphalt Concrete, Surface Course, Type 1, PG 64-22 (Driveways)	25.0 C.Y.	\$ 175.00	\$ 4,375.00
614	Maintaining Traffic, As Per Plan	1 Lump	\$ 2,275.00	\$ 2,275.00
617	Compacted Aggregate (RACP), As Per Plan	35 C.Y.	\$ 55.00	\$ 1,925.00
624	Mobilization	1 Lump	\$ 2,000.00	\$ 2,000.00
TOTAL				\$ 55,000.00